



सत्यमेव जयते

MINISTRY OF MICRO, SMALL & MEDIUM ENTERPRISES
GOVERNMENT OF INDIA



INFORMATION BROCHURE

2023-24



AS 9100,
ISO 9001:2015, ISO 14001:2015,
ISO 45001:2018 CERTIFIED

Central Tool Room & Training Centre
Bhubaneswar, Odisha



Profile

MSME Tool Room-Bhubaneswar (Central Tool Room & Training Centre, Bhubaneswar) within its 31 years of existence today stands as the premier Tool Room & Training Centre in India. The organization is established under the Technical Co-operation programme between Government of India and Denmark as a Govt. of India Society. The management of affairs of the centre rests with the governing council constituted by Govt. of India. Additional Secretary & Development Commissioner (MSME), Govt. of India, is the President of the Society & Chairman of the Governing Council.

MSME Tool Room- Bhubaneswar is on the way of achieving its set-goal with its extension centre at Rayagada (Border of Andhra Pradesh) Berhampur (Ganjam) & Kalinga Nagar (Jajpur), Odisha. It has set the benchmark among all the Tool Rooms & Training Centres under the Ministry of MSME for its quality industry - oriented training programmes in the field of Tool Design & manufacturing, Quality Assurance, Precision Component Manufacturing for Automobile & Aerospace Industries, CAD/CAE/CAM/CNC Technology/ Hardware Networking/ VLSI/ Industrial Automation (PLC) & Robotics/ Structural Design & Analysis for Different levels & disciplines Trainees.

In pursuit of excellence, the Tool Room has been awarded with AS 9100, ISO 9001:2015, ISO 14001:2015, ISO 45001:2018 Certifications.

Our Activities

PRODUCTION

TOOL DESIGN & MANUFACTURING

TOOL TRYOUT & PART PRODUCTION

QUALITY ASSURANCE

AEROSPACE MANUFACTURING

TRAINING

CAD / CAM / CAE

STRUCTURAL DESIGN & ANALYSIS

INDUSTRIAL AUTOMATION & ROBOTICS

VLSI & EMBEDDED SYSTEM

WE CONDUCT TAILOR MADE COURSES FOR

1. Courses For Foreign Nationals

4. Courses For Technical Institute

2. Courses For Industrial Professionals

5. Training of Trainers of Technical Institutes

3. Induction Training For Newly Recruits

6. Modular Training Programme

Training at a Glance

- Conducted Training Programme from School drop out to B.Tech pass out different level & different discipline students.
- CTTC, Bhubaneswar offers IGNOU certified & Hero authorized Hero Mechanic Programme for 8th pass students.
- CTTC, Bhubaneswar in collaboration with Samsung, India offers Advanced Repair & Industrial Skill Enhancement Programmes for various categories.
- We also offer Entrepreneurship Skill Development Programme under ESDP scheme of Govt. of India for skill enhancement in the sectors of CNC, CAD/ CAM, PLC, VLSI etc. for the students of 10th class onwards
- We also offer various skill development courses for the North East Region Youth under DONOR Programmes of Ministry of MSME.
- Giving the vocational direction to Youth for Development of Technical Skill
- Gainful employment in Hi Tech areas
- Entrepreneurial Skill with Techno – Commercial Knowledge
- Professional Ethics, Work Culture & Personality Development
- Awareness towards the Nation, Society & Environment



Training Achievements

- Received award of “Excellent Institute in Skill Development Programmes in ODISHA” in 2nd National Odisha Education Summit & Awards 2015
- Represented India in MCAD in “World Skill Competition 2022” held at Shanghai, China in Nov.’2022.
- Best Extension Centre model among all Technology Centre at Rayagada.
- Established CTTC brand in the country for Summer Vacation Training for Degree/Diploma Engineering Graduates.
- Conducted International Training for 25 countries.

For Details of other courses go to the following pages...



CAREER ORIENTED COURSES OF DIFFERENT LEVELS & DIFFERENT DISCIPLINES

LONG TERM & MEDIUM TERM COURSES				
COURSE NAME	COURSE CODE	TENTATIVE DATE	DURATION	PAGE
COURSES FOR 10TH PASS OUT				
Diploma in Tool & Die Making	DTDM	July	4 Years	7
Diploma in Mechantronics	DIM	July	3 Years	7
ITI Machinist	ITIM	July	2 Years	7
Condensed Course in Tool & Die Making	CTDM	August/March	1 Year	8
Certificate Course in CNC Turning & Milling	CCTM	August/November/February	1 Year	8
Certificate Course in CNC Milling	CCCM	July/December	6 Months	
Certificate Course in CNC Turning	CCCT	July/December	6 Months	
COURSES FOR UNDER MATRIC				
Certificate Course in Machine Operation	CCMO	August & February	1 Year	8
COURSES FOR ITI STUDENTS				
Certificate Course in Advance Machining	CCAM	Aug/Oct/Dec/Feb	1 Year	9
Advance Certificate Course in Machine Maintenance	ACCMM	Aug/Oct/Dec/Feb	1 Year	9
Advance Certificate Course in CNC Machining	ACCCM	Sept/March	1 Year	9
Advance Certificate Course in Welding Technology	ACCWT	August/February	1 Year	10
Certificate Course in Machining	CCM	September	6 Months	10
Certificate Course in Fitting & Rigging	CCFR	August	6 Months	10
COURSES FOR DIPLOMA IN MECHANICAL ENGG. OR EQUIVALENT				
Post Diploma in Tool & Die Making	PDTDM	July/Sep/Jan/Mar	1 Year	11
Post Diploma in CAD/CAM	PDCC	July/September	1 Year	11
Master Certificate Course in Product Design	MCCPD	July	6 Months	12
Advance Diploma in CNC Programming Techniques & Practice	ADCNC	May/July/Sep/Nov/Jan/ Mar	6 Months	12
COURSES FOR DEGREE IN MECHANICAL ENGG. OR EQUIVALENT				
Post Graduate Diploma in Tool Design & CAD/CAM	PGDTD	July/Nov/Jan	1 Year	13
Post Graduate in Aerospace Manufacturing	PGAM	July/November	1 Year	13
Master Certificate course in CAD/CAM	MCC	Apr/May/July/Aug/Nov/Jan	6 Months	14
COURSES FOR DIPLOMA IN ELECTRICAL ELECTRONICS ENGG. OR EQUIVALENT				
Advanced Diploma in Machine Maintenance & Automation	ADMMA	May/July/ Sep /Nov/Feb	6 Months	14
Advanced Embedded Technology	AET	May/July/Sep/Jan	6 Months	14
Certificate Course in Electrical Equipment Repair & Maintenance	CCERM	September	6 Months	15
Post Diploma in Industrial Automation & Robotics	PDIAR	July/December	1 Year	15
COURSES FOR DEGREE IN ELECTRICAL ELECTRONICS ENGG. OR EQUIVALENT				
Master Certificate Course in Automation & Process Control	MCCAPC	May/July/Sep/ Nov/Jan/Mar	6 Months	16
COURSES FOR DIPLOMA IN MECHANICAL/ ELECTRICAL/ELECTRONICS ENGG. OR EQUIVALENT				
Master Certificate Course in Mechatronics	MCCM	May/July/Oct/Jan	6 Months	16
Post Diploma in Mechatronics	PDIM	May/January	1 Year	17
COURSES FOR DIPLOMA/DEGREE IN CIVIL ENGG.				
Post Diploma in Structural Analysis & Project Management	PDSPM	June/October/February	1 Year	18
Advance Diploma in Structural Design & Analysis	ADSDA	May/July/Sep/Nov/Jan/Mar	6 Months	18
COURSES FOR ANY GRADUATE				
Advance Certificate Course in Inspection & Quality Control	ACCIQC	August/November/January	6 Months	19
Advance Diploma in Computer Hardware & Networking Management	ADCHNM	May/July/Sep/Nov/Jan/Mar	6 Months	19
Advanced Certificate Course in Software Application	ACCSA	May/October/February	6 Months	19

LONG/MEDIUM TERM TRAINING PROGRAMMES SCHEDULE FOR 2023 - 2024

DATE	APRIL	2023	DATE	OCTOBER	2023
03.04.2023	MCC	99 th BATCH	10.10.2023	CCAM	90 th BATCH
18.04.2023	CCCT/ACCMM	20 th /73 rd BATCH	11.10.2023	ACCMM	75 th BATCH
DATE	MAY	2023	17.10.2023	CCNA/SURYAMITRA	25 th /2 nd BATCH
09.05.2023	MCC	100 th batch	18.10.2023	ACCSA/PDSPM	12 th /1 7 th BATCH
10.05.2023	MCCAPC/AET	47 th /50 th BATCH	DATE	NOVEMBER	2023
11.05.2023	ADCHNM	142 nd BATCH	01.11.2023	PGDTD/PGAM	37 th /16 th BATCH
16.05.2023	ADSDA/PDIM	56 th /8 th BATCH	03.11.2023	CCCTM/ACCIQC	40 th /16 th BATCH
17.05.2023	ADCNC	107 th BATCH	07.11.2023	MCC/ACCCM	103 rd /48 th BATCH
23.05.2023	ADMMA/ACCSA	73 rd /11 th BATCH	08.11.2023	ADCHNM/SAMSUNG	145 th /38 th BATCH
24.05.2023	SAMSUNG/CCNA	35 th /23 rd BATCH	14.11.2023	MCCAPC	50 th BATCH
DATE	JUNE	2023	21.11.2023	ADSDA	59 th BATCH
21.06.2023	SURYAMITRA	1 st batch	22.11.2023	ADCNC	110 th BATCH
22.06.2023	PDSPM/PDTDCC	16 th /3 rd BATCH	28.11.2023	ADMMA	76 th BATCH
DATE	JULY	2023	DATE	DECEMBER	2023
03.07.2023	DTDM/DIM	33 rd /12 th BATCH	01.12.2023	CCCT	22 nd BATCH
04.07.2023	PDTDM/PDCC	59 th /35 th BATCH	06.12.2023	CCCM	11 th BATCH
05.07.2023	PGDTD/CCCT	36 th /21 st BATCH	12.12.2023	CCAM	91 st BATCH
06.07.2023	MCCAPC/AET	42 th /51 th BATCH	13.12.2023	ACCMM	76 th BATCH
07.07.2023	CCCM	10 th BATCH	19.12.2023	PDIAR	16 th BATCH
11.07.2023	MCC	101 st BATCH	20.12.2023	CCNA/PDTDCC	26 th /4 th BATCH
12.07.2023	PGAM	15 th BATCH	DATE	JANUARY	2024
14.07.2023	PDIAR	15 th BATCH	02.01.2024	*PGDTD	38 th BATCH
18.07.2023	ADSDA	57 th BATCH	03.01.2024	PDTDM/PDCC	61 st /37 th BATCH
19.07.2023	ADCNC	108 th BATCH	04.01.2024	PDIM	9 th BATCH
25.07.2023	ADMMA	74 th BATCH	09.01.2024	*MCC	104 th BATCH
26.07.2023	ADCHNM/SAMSUNG	143 rd /36 th BATCH	10.01.2024	*MCCAPC	51 st BATCH
DATE	AUGUST	2023	17.01.2024	*AET	53 rd BATCH
01.08.2023	ITI MACHINIST	18 th BATCH	18.01.2024	ADCHNM/SAMSUNG	146 th /39 th BATCH
02.08.2023	CCCTDM/ACCIQC	32 nd /1 5 th BATCH	19.01.2024	ACCIQC	17 th BATCH
04.08.2023	CCCTM	39 th BATCH	23.01.2024	ADSDA	60 th BATCH
09.08.2023	ACCWT	17 th BATCH	24.01.2024	ADCNC	111 th BATCH
10.08.2023	CCMO	19 th BATCH	DATE	FEBRUARY	2024
16.08.2023	CCAM	89 th BATCH	06.02.2024	CCCTM/PDSPM	41 st /1 8 th BATCH
17.08.2023	ACCMM/CCFR	74 th /1 st BATCH	07.02.2024	ACCWT/CCMO	18 th /20 th BATCH
22.08.2023	MCC	102 nd BATCH	13.02.2024	ADMMA	77 th BATCH
23.08.2023	CCNA	24 th BATCH	20.02.2024	CCAM/CCCT	92 nd /23 rd BATCH
DATE	SEPTEMBER	2023	21.02.2024	ACCMM	77 th BATCH
01.09.2023	PDTDM/PDCC	60 th /36 th BATCH	27.02.2024	CCNA/ACCSA	27 th /13 th BATCH
05.09.2023	ACCCM	47 th BATCH	DATE	MARCH	2024
12.09.2023	MCCAPC/AET	49 th /52 nd BATCH	01.03.2024	PDTDM	62 nd BATCH
13.09.2023	CCERM	8 th BATCH	05.03.2024	CCCTDM	33 rd BATCH
14.09.2023	ADCHNM/SAMSUNG	144 th /37 th BATCH	06.03.2024	ACCCM	49 th BATCH
15.09.2023	CCM	6 th BATCH	12.03.2024	MCCAPC	52 nd BATCH
20.09.2023	ADSDA	58 th BATCH	19.03.2024	ADSDA	61 st BATCH
21.09.2023	ADCNC	109 th BATCH	20.03.2024	ADCNC	112 th BATCH
26.09.2022	ADMMA	75 th BATCH	22.03.2024	ADCHNM/SAMSUNG	147 th /40 th BATCH

* Special Internship Training for B-Tech final year students.



CAREER ORIENTED COURSES OF DIFFERENT LEVELS & DIFFERENT DISCIPLINES

SHORT TERM COURSES

COURSE NAME	DURATION	PAGE NO.
COURSES FOR DIPLOMA/DEGREE IN MECHANICAL ENGG. OR EQUIVALENT		
Auto CAD (Mechanical)	1 Month	20
UNIGRAPHICS	1 Month	20
MASTER CAM	1 Month	20
CATIA	1 Month	21
Creo	1 Month	21
SOLIDWORKS	1 Month	21
CNC Milling/Turning	1 Month	21
Additive Manufacturing & 3D Scanning	1 Month	21
ANSYS	15 Days	22
3D Printing	15 Days	22
COURSES FOR DIPLOMA/DEGREE IN ELECTRONICS ENGG. OR EQUIVALENT		
PLC	1 Month	23
VLSI	1 Month	23
SCADA	1 Month	24
Advanced Embedded System	1 Month	24
ROBOTICS	1 Month	24
Hydraulics & Pneumatics	1 Month	24
E.CAD	1 Month	24
Lab View	15 Days	24
Electrical machine Lab	15 Days	24
Suryamitra (Solar PV Installation)	1.5 Months	24
Process Automation	1 Month	24
Mechatronics	1 Month	24
COURSES FOR DIPLOMA/DEGREE IN CIVIL ENGG.		
Auto CAD (Civil)	1 Month	25
STAAD PRO	1 Month	25
3Ds Max	1 Month	25
REVIT	1 Month	25
COURSES FOR ANY GRADUATE		
MAT LAB	15 Days	26
Internet of Things (IOT)	1 Month	26
Core JAVA	1 Month	26
Programming in C	1 Month	27
Programming in C++	1 Month	27
Entrepreneurship Skill Development Program	15 Days	28
Hardware Networking	1 Month	28
Soft Skill	1 Month	29
CCNA	4 Months	30
Windows Server Administration	1 Month	30
Artificial Intelligence & Machine Learning	1 Month	30
Python	1 Month	30
SAP Business One	8 Days	30
Data Analytics	1 Month	30
SAMSUNG ARISE COURSES FOR +2 SCIENCE/ITI/DIPLOMA/DEGREE STUDENTS		
Hand Held Product (Mobile Repairing)	3 Months	30
LED, LCD, Plasma TV, Home Theatre (A-V)	3 Months	30
Room Air Conditioner & Home Appliances	4 Months	30

N.B: For details of Course Objective, Content and Course Fee follow respective pages

* Assessment Fee of Rs. 100/- will be charged excluding the Course Fee for above courses.

TRAINING PROGRAMMES

COURSES FOR HSC / SSLC STUDENTS

1. DIPLOMA IN TOOL & DIE MAKING (DTDM) - [AICTE Approved]

- Objectives** : After completion of the course, the Trainees will be able to design & manufacture different types of tools & dies using CAD/CAM software & all kind of conventional & CNC machine.
- Duration** : 4 Years
- Course Content** : Equivalent to Diploma in Mechanical Engg. With TOOL/Mould/Die/Fixture Designing & Manufacturing.
N.B. : Course contains 70% Practical & 30% Theory.
- Mode of Selection** : Selection will be based on all India level Entrance Examination
- Course Starts on** : July
- Course Fee** : ₹.19,000/- (per semester)



2. DIPLOMA IN MECHATRONICS (DIM) - [AICTE Approved]

- Objectives** : After completion of the course, the Trainees will be able to work in different types of mechanical as well as electronics machineries and can be able to manufacture different mechatronics components.
- Duration** : 3 Years
- Course Content** : Combined subjects of Mechanical, Electrical & Electronics
N.B. : Course contains 70% Practical & 30% Theory.
- Mode of Selection** : Selection will be based on all India level Entrance Examination
- Course Starts on** : July
- Course Fee** : ₹.19,000/- (per semester)



3. ITI MACHINIST - [NCVT Approved]

- Duration** : 2 Years
- Course Content** : As per NCVT Syllabus
- Mode of Selection** : Selection will be based on HSC mark
- Course Starts on** : July
- Course Fee** : ₹.28,000/- (per year)
- Course Location** : For Machinist- CTTC, Bhubaneswar





6. CONDENSED CERTIFICATE COURSE IN TOOL & DIE MAKING (CTDM) - [NSQF Level : 4]

- Objectives** : After completion of the course, the trainees will be able to handle all types of machine as well as can manufacture different types of tool & die.
- Job Role** : Skilled Technician/Tool and Die Maker
- Duration** : 1 Year
- Course Content** : Semester-I : Production technology, Auto CAD, Part Programming, Master Cam, Press Tool Design, CNC Technology, Engineering Drawing, Material Technology, Metrology, Press Tool Theory
Semester-II : Press Tool Design, Mold Manufacturing, Modern Manufacturing Technology, Jigs and Fixture, Mold Theory, Communicative English, Industrial Management, In plant Training & Project Work
- Mode of Selection** : First come first serve basis
- Course Starts on** : March & August
- Course Fee** : ₹.66,000/-



7. CERTIFICATE COURSE IN CNC TURNING & MILLING (CCTM) - [NSQF Level : 4]

- Objectives** : After completion of the course, the trainees will be able to handle all tool room machine (Conventional & CNC Machines) manufacture any type of job according to the demand, independently..
- Job Role** : CNC Operator
- Duration** : 1 Year
- Course Content** : Engineering Drawing, Engineering Metrology, Workshop Technology-Theory & Practical, Workshop Calculation, Quality Management System, Group Discussion and Personality Improvement, CNC Programming & CNC Machining-Theory & Practical, Computer Aided Drafting & Design(AutoCAD), Computer Aided Manufacturing (Master CAM), Employability skill, CNC PROGRAMMING AND CNC MACHINING - On job training
- Mode of Selection** : First come first serve basis
- Course Starts on** : August, November & February
- Course Fee** : ₹.32,000/-(In two instalments)



COURSES FOR UNDER MATRIC STUDENTS

1. CERTIFICATE COURSE IN MACHINE OPERATION (CCMO) - [NSQF Level : 3]

- Objectives** : After completion of the course, the Trainees will be able to do machining operation in all conventional machines as well as can manufacture components.
- Job Role** : Technician / Machine Tool Operator
- Duration** : 1 Year
- Course Content** : Conventional Machine Practice, Machine Shop - Theory, Engineering Metrology, Engineering Drawing, Workshop Calculation and Science, Employability Skills
- Mode of Selection** : First come first serve basis
- Course Starts on** : August, February
- Course Fee** : ₹.18,000/-



TRAINING PROGRAMMES

COURSES FOR ITI STUDENTS

1. CERTIFICATE COURSE IN ADVANCED MACHINING (CCAM) – For ITI Fitter - [NSQF Level : 5]

- Objectives** : After completion of the course, the Trainees will be able to impart new skill in Advance Machining & able to do work in Fitting & Assembly Area.
- Job Role** : Skilled Conventional and CNC Machine Operator
- Duration** : 1 Year
- Course Content** : Semester-1 : Production Technology, AutoCAD, Engineering drawing, Metrology, Communication Skill
Semester-2 : Advance Conventional Machining, CNC Lathe, CNC Milling, Non-Conventional Machining, Engineering Drawing, Material Technology, Entrepreneurship, In-plant Training
- Mode of Selection** : Selection will be based on merit list prepared to 40% mark of HSC + 60% of ITI mark
- Course Starts on** : August, October, December & February
- Course Fee** : ₹.32,000/-(In two instalments)



2. ADVANCE CERTIFICATE COURSE IN MACHINE MAINTENANCE (ACMM) – For ITI Fitter/Electrician - [NSQF Level : 5]

- Objectives** : After completion of the course, the Trainees will be able to do maintenance of conventional machines & CNC Turning & Milling. Trainees will also be trained on computers.
- Job Role** : Maintenance Technician
- Duration** : 1 Year
- Course Content** : Semester-1 : Conventional milling, Conventional turning, Fitting & bench work, Use of safety practice in industry, Work efficiently at workplace, Computer fundamentals & AutoCAD, Basic Electricals & Transmission control, Preventive & Breakdown Maintenance of Conventional Machine tools like Lathe, Milling, Grinding, Drilling, etc.
Semester-2 : Programmable Logic Controller(PLC), Air Compressor, Pumps, DG Set, Uninterrupted Power Supply, CNC Machines
- Mode of Selection** : Selection will be based on merit list prepared to 40% mark of HSC + 60% of ITI mark.
- Course Starts on** : August, October, December & February
- Course Fee** : ₹.32,000/-(In two instalments)



3. ADVANCE CERTIFICATE COURSE IN CNC MACHINING (ACCCM) – For ITI Machinist & Fitter - [NSQF Level : 5]

- Objectives** : After completion of the course, the trainees will be able to handle all tool room machine (Conventional & CNC Machines) manufacture any type of job according to the demand, independently in CNC machining area.
- Job Role** : CNC Operator
- Duration** : 1 Year
- Course Content** : CNC Programming & CNC Machining, Engineering Metrology and Quality Assurance-THEORY & PRACTICAL, Production Planning & Controls, Computer Aided Manufacturing (Master Cam), Advance Cam (DEL CAM – 3 Axis And 5 Axis), Total quality management, Fundamentals of Metal Cutting Tool, Entrepreneurship, Project Work
- Mode of Selection** : Selection will be based on merit list prepared to 40% mark of HSC + 60% of ITI mark.
- Course Starts on** : September, November & March
- Course Fee** : ₹.34,000/-(in two instalments)





4. Advanced Certificate Course in Welding Technology (ACCWT) – [NSQF Level : 5]

- Objectives** : After completion of the course, the Trainees will be able to do all kind of fabrication work using various welding methods as well as can inspect the welding, identify the defects & can make the remedies.
- Job Role** : Welding Technician
- Duration** : 1 Year
- Course Content** : Personality Development & Computer Literacy, Engg. Calculation & Science, Engg. Drawing, Welding Technology (Theory), Welding Techniques using Various Weld Methods
- Mode of Selection** : First come first serve basis
- Course Starts on** : August & February
- Course Fee** : ₹.50,000/-



5. Certificate Course in Machining (CCM) – [NSQF Level :5]

- Objectives** : After completion of the course, the Trainees will be able to operate Conventional Tool Room Machines
- Job Role** : Skilled Technician/ Machinist
- Duration** : 6 Months
- Course Content** : Production Technology, Engg. Drawing, Engg. Metrology, Fundamentals of Computer, AutoCAD, Soft Skill
- Mode of Selection** : First come first serve basis
- Course Starts on** : September
- Course Fee** : ₹.22,000/-



6. Certificate Course in Fitting & Rigging (CCFR) – [NSQF Level :3]

- Objectives** : Maintenance of Industrial equipment (Hydraulic, Pneumatic, Mechanical & Electrical), Lifting equipment
- Job Role** : Maintenance Technician & Rigger
- Duration** : 6 Months
- Course Content** : Fitting, Machining, Hydraulic, Pneumatic, Maintenance of gear, Belt, Pump
- Mode of Selection** : First come first serve basis
- Course Starts on** : August
- Course Fee** : ₹.22,000/-



TRAINING PROGRAMMES

COURSES FOR DIPLOMA IN MECHANICAL/ PRODUCTION/ AUTOMOBILE OR EQUIVALENT ENGG.

1. POST DIPLOMA IN TOOL & DIE MAKING (PDTDM) - [NSQF Level : 6]

- Objectives** : After completion of the course, the trainees will be able to manufacture of different tools & dies using Tool room machines, CNC technology and CAM software.
- Job Role** : Tool Room Engineer
- Duration** : 1 Year
- Course Content** : CNC Programming & CNC Machine Practice, Computer Aided Design (AUTO CAD AND SOLID WORKS), Fundamentals Of Tools & Dies, Engineering Metrology And Quality Assurance, Production Planning & Controls, Computer Aided Manufacturing (MASTER CAM & NX CAM), Advance CAM (DEL CAM – 3 AXIS AND 5 AXIS), Engineering Materials And Heat Treatment, Total Quality Management, Metal Cutting & Cutting Tool Design, Entrepreneurship, Project Work
- Mode of Selection** : First Come First Serve Basis
- Course Starts on** : July, September, January & March
- Course Fee** : ₹.54,000/- (In three instalments)



2. POST DIPLOMA IN CAD/ CAM (PDCC) - [NSQF Level : 6]

- Objectives** : After completion of the course, the Trainees will be able to do design & analysis of different engineering application through latest CAD/CAE software & simultaneously to operate CNC machine by preparing programme through latest CAM software.
- Job Role** : CAD CAM Technologist
- Duration** : 1 Year
- Course Content** : Engineering Drawing, Computer Fundamentals and Auto Cad, Master CAM, CNC Part Programming & Machine Practice, Solid works, Unigraphics (NX), Creo Parametric, CATIA, Work NC, Finite Element Analysis (FEA), Reverse Engineering, Safety & Maintenance, Basic Engineering Concepts, Entrepreneurship and Managerial Skills, Project
- Mode of Selection** : First Come First Serve Basis
- Course Starts on** : July, September & January
- Course Fee** : ₹.54,000/- (In three instalments)

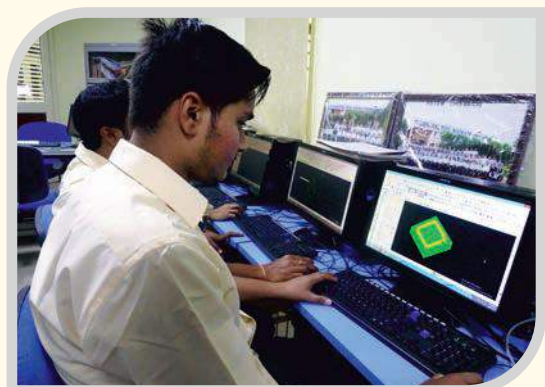



3. MASTER CERTIFICATE COURSE IN TOOL DESIGN (MCCTD) - [NSQF Level : 6]

- Objectives** : After completion of the course, the trainees will be able to design & analyse different type of Tools & other engineering application (through latest CAD/CAE software) simultaneously they can manufacture different type of tool & precision components using modern manufacturing techniques through latest CAM Software.
- Job Role** : Tool Designer
- Duration** : 6 Months (8 hrs./day)
- Course Content** :
1. Software: Auto CAD, Solid works & Unigraphics
 2. Theory:
 - Review of engineering subjects.
 - Press tool & mould design(practical oriented)
 - ISO, 5s, Kaizen
 3. Soft skill: Communication skill, personality development, GD, interview techniques, resume preparation & mock interview.
 4. Workshop exercise: Hand injection mould, Jig & Fixture, Simple Press Tool, Semi- Automatic Injection Mould, Progressive Press Tool
- Mode of Selection** : First Come First Serve Basis
- Course Starts on** : September
- Course Fee** : ₹.34,000/-(in two instalments)



4. ADVANCED DIPLOMA IN CNC PROGRAMMING TECHNIQUES & PRACTICE (ADCNC) - [NSQF Level : 6]

- Objectives** : After completion of the course, the trainees will be a successful CNC programmer & CNC supervisor simultaneously they can also design different components using CAD software.
- Job Role** : CNC Programmer
- Duration** : 06 Months
- Course Content** :
- Production Technology (Introduction to Workshop Technology), AutoCAD (Drafting and modeling using Auto CAD), CNC Programing & CNC Machine Practice, Master CAM (Modelling and programming using Master-CAM), Unigraphics (Modelling and programming using Unigraphics), Engineering Drawing (Study of engineering drawing), METROLOGY (Application of metrology in manufacturing), MATERIAL TECHNOLOGY (Use of materials with respect to their application and properties), Communication Skill (Communication at Workplace), PROJECT WORK
- Mode of Selection** : First Come First Serve Basis
- Course Starts on** : May, July, September, November, January & March
- Course Fee** : ₹.34,000/-(in two instalments)



TRAINING PROGRAMMES

COURSES FOR DEGREE IN MECHANICAL/ PRODUCTION/ AUTOMOBILE OR EQUIVALENT ENGG.

1. POST GRADUATE DIPLOMA IN TOOL DESIGN & CAD/CAM (PGDTD) – [NSQF Level : 8]

- Objectives** : After completion of the course, the trainees will be able to work in design department to carry out designing of different tools & dies using CAD CAM software.
- Job Role** : Tool Designer or CAD CAM Engineer
- Duration** : 1 Year (8Hrs./ Day)
- Course Content** : CNC Programming & CNC Machine Practice, Computer Aided Design (Auto CAD and Solidworks), Computer Aided manufacturing (Master CAM & NX CAM), Design of Jigs & Fixtures, Design of Press Tool, Design of Die Casting Die, Advance Metrology, Advanced CAD-I (NX & CATIA), Manufacturing Process - Process Planning and Heat Treatment, Advanced CAD- II (Creo), Computer Aided Engineering (ANSYS), Rapid Prototyping and Reverse Engineering, Entrepreneurship, Engineering Research Methodology, Project work
- Mode of Selection** : First Come First Serve Basis
- Course Starts on** : July, November & January
- Course Fee** : ₹. 60,000/- (In four instalment)



2. POST GRADUATE IN AEROSPACE MANUFACTURING (PGAM) – [NSQF Level : 8]

- Objectives** : Participants will be able to work in Conventional, CNC machines, Assembly & fitting area, Work in sheet metal industries / plastic industries. Type of tools, maintenance and trouble shooting of problems.
- Job Role** : Entrepreneur / Engineer (Production/Process Planing & Quality Control)
- Duration** : 1 Year (3 Months in Training Dept. & 9 Months in Production Dept.)
- Course Content** : **Semester-I** : Production Technology, AutoCAD, CNC Technology, Master cam, Engineering Drawing, Metrology, Material Technology, Heat Treatment, Surface Coating & Cleaning, Soft Skill, **Semester-II** : Hyper Mill, CATIA, QMS and FAI, AS 9100, Quality Control & Inspection, HYPER MILL, Selection of Cutting Tools, Strength of Material, Process Plan, Theory of Sheet Metal
- Mode of Selection** : First Come First Serve Basis
- Course Starts on** : July & November
- Course Fee** : ₹.60,000/- (In three instalment)





4. MASTER CERTIFICATE COURSE IN CAD/CAM (MCC) – [NSQF Level : 6]

- Objectives** : After completion of the course, the trainees will be able to work in design department and to carry out designing using various CAD software, can develop CAM programme using CAM software & analysis of different component using CAE software
- Job Role** : CAD CAM Engineer
- Duration** : 6 Months (8 hrs./day)
- Course Content** : Computer Aided Design (CAD-Auto CAD and Solid works), Computer Aided Design & Computer Aided manufacturing (Unigraphics CAD & Unigraphics CAM), Computer Aided Engineering (ANSYS), Advance Computer Aided Design(CREO Parametric and CATIA), CNC Programming And CNC Machining, Related Theory Subjects (Engineering Drawing, Engineering Metrology, Strength of Material, Engineering Material, Production Technology), Entrepreneurship, Project Work
- Mode of Selection** : First Come First Serve Basis
- Course Starts on** : May, July, August, November & January
- Course Fee** : ₹.36,000/-(in two instalments)



TRAINING PROGRAMMES COURSES FOR DIPLOMA IN ELECTRICAL OR ELECTRONICS ENGG.

1. ADVANCED DIPLOMA IN MACHINE MAINTENANCE & AUTOMATION (ADMMA) – [NSQF Level : 6]

- Objectives** : After completion of the course, the trainees should be able to perform maintenance activities of workshop machineries.
- Job Role** : Entrepreneur/ Maintenance & Automation Engineer
- Duration** : 6 Months (6 hrs./day)
- Course Content** : Machine Operation, Electrical Hardware Logic Control, Electrical Machines, Pneumatics & Hydraulics, Machine Maintenance, Programmable Logic Controller, SCADA & HMI, TIA- Portal, Communication Skill, AutoCAD Electrical, Basic Electronics
- Mode of Selection** : First Come First Serve Basis
- Course Starts on** : May, July, September, November & February
- Course Fee** : ₹.34,000/-(in two instalments)



2. ADVANCED EMBEDDED TECHNOLOGY (AET) – [NSQF Level : 6]

- Objectives** : After completion of the course, the trainees should be able to work on embedded hardware and software also design printed circuit board.
- Job Role** : Junior Embedded Engineer / PCB Designer
- Duration** : 6 Months (6 hrs./day)
- Course Content** : PIC Microcontroller, Embedded C/C++, Communication protocol & Implementation, Robotics- Interfacing with Motors and Sensors, ARM-Advanced RISC Machine(LPC2148), Concept of RTOS, VLSI Design with FPGA/CPLD, PCB Designing, Python Programming on Raspberry Pi, Project Work
- Mode of Selection** : First Come First Serve Basis
- Course Starts on** : May, July, September & January
- Course Fee** : ₹.34,000/-(in two instalments)



3. CERTIFICATE COURSE IN ELECTRICAL EQUIPMENTS, REPAIRING & MAINTENANCE (CCERM) - [NSQF Level : 6]

- Objectives** : After completion of the course, the Trainees will be able to work with electrical wiring high voltage motor and work on estimation & costing.
- Job Role** : Technical Assistant and Maintenance Engineer
- Duration** : 6 Months
- Course Content** : Basic safety regarding use of electricity, Fundamentals on hand tools, Basic electrical and electronics, Domestic and industrial wiring, Repairing of home appliances, Repairing of washing machine, Repairing of air conditioner and refrigerator, Repairing of water purifier and geyser, Repairing, winding and maintenance of motor and pump, Soft Skill
- Mode of Selection** : First Come First Serve Basis
- Course Starts on** : September
- Course Fee** : ₹. 34,000/- (In two instalments)



4. POST DIPLOMA IN INDUSTRIAL AUTOMATION & ROBOTICS (PDIAR) – [NSQF Level : 6]

- Objectives** : After completion of the course, the trainees should be able to fit to work in Electrical Engineering & Electronics Engineering automation field as well as can be able to work in industrial robots.
- Job Role** : Automation Supervisor & Robotic Engineer
- Duration** : 1 Year (6hrs./Day)
- Course Content** : To have broad knowledge of Automation Techniques, Robotics and Automation systems, Drives, Hydraulics & Pneumatics. To apply Automation and Robotics principles for solutions to the specific problems. To use software for generating solutions in PLC, Hydraulics & Pneumatics. To work as individual & member of inter discipline team in the management supervision. To communicate effectively. To use mathematical skills for solving specific problems. To work on project & have good data collecting, organizing ability. To observe & follow safety. Develop entrepreneurship skills. Generate and update customizable reports and data in presentable form, interpret drawings, draw interferences and workout other technical details. Explain energy flow in electrical, pneumatic and hydraulic sub-systems.
- Mode of Selection** : First Come First Serve Basis
- Course Starts on** : July & December
- Course Fee** : ₹.54,000/- (in three instalments)





TRAINING PROGRAMMES COURSES FOR DEGREE IN ELECTRICAL OR ELECTRONICS ENGG.

1. MASTER CERTIFICATE COURSE IN AUTOMATION & PROCESS CONTROL (MCCAPC) – [NSQF Level : 7]

- Objectives** : After completion of the course, the trainees should be able to work in power plant, packaging industries, FMCG area as well as can work in process automation area.
- Job Role** : Entrepreneur/Process Control/Automation Engineer
- Duration** : 6 Months (6hrs./day)
- Course Content** : Electrical Hardware Logic Control, Electrical Machines, Sensor and transducer, Pneumatics & Hydraulics system, Programmable Logic Controller, Embedded System, Machine Maintenance, SCADA & HMI, TIA- Portal, Distributed control system by PCS-7, Lab view, Robotics, AUTOCAD Electrical, Communication Skill
- Mode of Selection** : First Come First Serve Basis
- Course Starts on** : May, July, September, November, January & March
- Course Fee** : ₹.36,000/- (in two instalments)



TRAINING PROGRAMMES COURSES FOR DIPLOMA/ DEGREE IN MECHANICAL/ ELECTRICAL/ ELECTRONICS

1. MASTER CERTIFICATE COURSE IN MECHATRONICS (MCCM) – [NSQF Level : 6]

- Objectives** : After completion of the course, the Trainees will be able to work in are if mechatronics, robotics and automation.
- Job Role** : Mechatronics Supervisor, System Programmer, Maintenance Supervisor
- Duration** : 6 Months
- Course Content** :
- PLC
 - Hydraulics & Pneumatics.
 - Mechatronics Principles.
 - Automation Techniques
 - Mechatronics Systems
 - Drives & Sensors
 - Data actuation system (lab view)
 - VLSI
 - Basic Electronics`
 - Electrical Machine lab
 - SCADA
 - ECAD
 - IOT
 - Soft Skill
- Mode of Selection** : First Come First Serve Basis
- Course Starts on** : January, May, July, October
- Course Fee** : ₹.34,000/- (in two instalments)



2. POST DIPLOMA IN MECHATRONICS (PDIM) – [NSQF Level : 6]

Objectives : After completion of the course, the Trainees will be able to work in are of mechatronics.

Job Role : Machatronics Engineer / Team Leader

Duration : 1 Year

- Course Content** :
- Describe the techniques that are of used to design a mechatronics process
 - Analyze different quality control Parameters and conduct audits for different quality standards
 - Analysis of the electrical circuits, magnetic circuits, circuit elements, equipment's and accessories, type of sensors, and derives
 - Design and manage instrument and sensor networks and associated synchronization problems
 - List the technical specifications of high-sensitivity and high frequency measurement equipment, Power devices for engineering tasks
 - Generate and update customizable reports and data in presentable form, interpret drawings, draw interferences and workout other technical details
 - Design circuits with different elements to meet the functionality requirement of products
 - Identify, formulate, and develop solution for maintenance problems
 - Prepare conceptual design & test against standards & parameters
 - Development of modern integrated environments for microcontroller programming and their features for simulation, testing and debugging
 - Develop the creative solutions using different programming techniques for mechatronics applications, including Input Output interface and communication peripherals
 - Explain energy flow in electrical, pneumatic and hydraulic sub-systems
 - Develop Programmes to actuate a physical system
 - Work effectively with others
 - Use basic Health and safety practices at work place
 - Develop entrepreneurship skills
 - Demonstrate the intellectual independence by completing the project work in Mechatronics.



Mode of Selection : First Come First Serve Basis

Course Starts on : May & January

Course Fee : ₹.54,000/- (In three instalment)



TRAINING PROGRAMMES

COURSES FOR DIPLOMA / DEGREE IN CIVIL ENGG.

1. POST DIPLOMA IN STRUCTURAL DESIGN & PROJECT MANAGEMENT (PDSPM) – [NSQF Level : 6]

- Objectives** : After completion of the course, trainees will be able to know different type of Structural design & Analysis in Detail.
- Job Role** : Site Engineer / Site Supervisor / Project Assistant
- Duration** : 1 Year
- Course Content** : Auto cad in civil, STAAD –Pro, 3Ds max, Revit architecture, Adobe Photoshop, GPS, MS office, Total station, Strength of material, Estimating & costing, Engineering drawing, Soft Skill, DGPS, Survey, Auto Level
- Mode of Selection** : First Come First Serve Basis
- Course Starts on** : June, October & February
- Course Fee** : ₹.54,000 (In three instalments)



2. ADVANCED DIPLOMA IN STRUCTURAL DESIGN & ANALYSIS (ADSDA) – [NSQF Level : 6]

- Objectives** : After completion of the course, trainees will be able to know different type of Structural design & Analysis.
- Job Role** : Site Engineer / Site Supervisor / Project Assistant
- Duration** : 06 Months
- Course Content** : Auto CAD in Civil, STAAD –Pro, 3Ds Max, Revit Architecture, Adobe Photoshop, Auto level, GPS, MS office, Total station, Strength of material, Estimating & costing, Engineering drawing, Soft Skill
- Mode of Selection** : First Come First Serve Basis
- Course Starts on** : May, July, September, November, January & March
- Course Fee** : ₹.34,000 (In two instalments)



TRAINING PROGRAMMES

COURSES FOR ANY GRADUATE

1. ADVANCE CERTIFICATE COURSE IN INSPECTION & QUALITY CONTROL (ACCIQC) – [NSQF Level : 5]

- Objectives** : During training, trainees will able to work on Quality control & Inspection.
- Job Role** : Quality Control Inspector / Job Inspector
- Duration** : 6 Months
- Course Content** : Engineering Drawing, Engineering Metrology, Workshop Calculation, Total Quality Management, AutoCAD, Master CAM, NX (UNIGRAPHICS), Inspection (CMM), Employability skill, Inspection & Quality Control -On Job Training
- Mode of Selection** : First Come First Serve Basis
- Course Starts on** : August, November & January
- Course Fee** : ₹.22,000/-(In two instalments)



2. ADVANCED DIPLOMA IN COMPUTER HARDWARE NETWORKING & MANAGEMENT (ADCHNM) – [NSQF Level : 6]

- Objectives** : After completion of the course, the trainees should be confident enough to solve day – to –day computer related problems.
- Job Role** : Hardware & Network Associates / System Service Engineer
- Duration** : 6 Months (8 hrs./day)
- Course Content** : Power Supply, PC Architecture, Software Installation, Up gradation & Maintenance, Network Essential, setup & management, Network management & server configuration, LINUX management & network configuration, Basic Electronics, Office Package, Communication Skill
- Mode of Selection** : First Come First Serve Basis
- Course Starts on** : July, September, November, January, March & May
- Course Fee** : ₹.34,000/-(in two instalments)



3. ADVANCE CERTIFICATE COURSE IN SOFTWARE APPLICATION (ACCSA)

- Objectives** : Prepare trainees who will be successful & professional in industry, government, academic, entrepreneurial pursuit & consulting firms & apply knowledge of Computer Science.
- Job Role** : An ability to identify, critically analyse, formulate & develop Computer applications.
- Duration** : 6 Months (8 hrs./day)
- Course Content** : C programming, C++, Core Java, Oracle, html, CSS, Advance Java, Project Work.
- Mode of Selection** : First Come First Serve Basis
- Course Starts on** : May & February
- Course Fee** : ₹.22,000/-(in two instalments)





TRAINING PROGRAMMES

SHORT TERM COURSES

COURSES FOR MECHANICAL/ PRODUCTION/ AUTOMOBILE OR EQUIVALENT ENGG.

1. AUTO CAD (MECHANICAL)

- Creating Objects
- Editing Objects
- Layers, Colour & Linetype
- Dimensioning & Tolerancing
- Blocks, Attributes & X-ref
- Layout, Plotting & Printing
- 3D Modelling

Duration : 1 Month (3hrs/ Day)

Course Fee : ₹.7,000/-

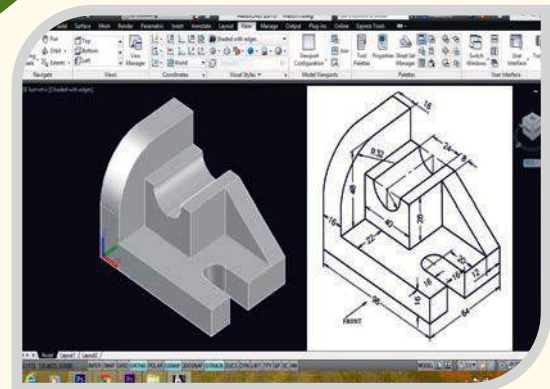

2. MASTER CAM

- 2D Drafting
- Wire Frame Modelling
- Surface Modelling
- Toolpath Generation
- Post Processing & DNC

Duration : 1 Month (3hrs/ Day)

Course Fee : ₹.8,000/-

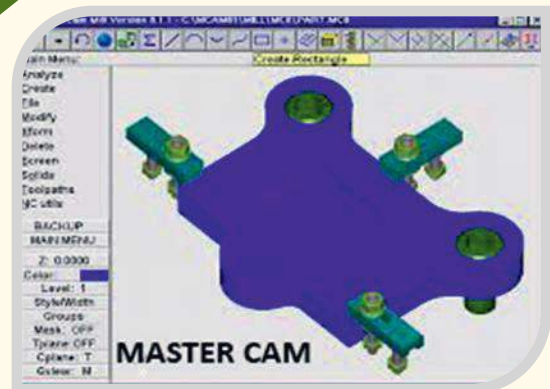

3. UNIGRAPHICS

- Introduction to Unigraphics
- Concept of Sketch & Constraint
- Part Modelling (Solid & Surface)
- Assembly
- Drafting & Detailing
- UG Manufacturing (Milling & Lathe)
- Post Processing & DNC

Duration : 1 Month (3hrs/ Day)

Course Fee : ₹.8,000/-

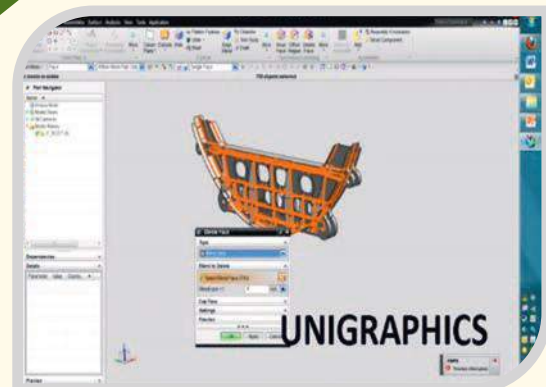

4. CREO

- Introduction to Creo
- Sketcher & Constraint
- Part Modelling
- Pro Surface
- Assembly Modelling
- Drafting & Detailing

Duration : 1 Month (3hrs/ Day)

Course Fee : ₹.8,000/-

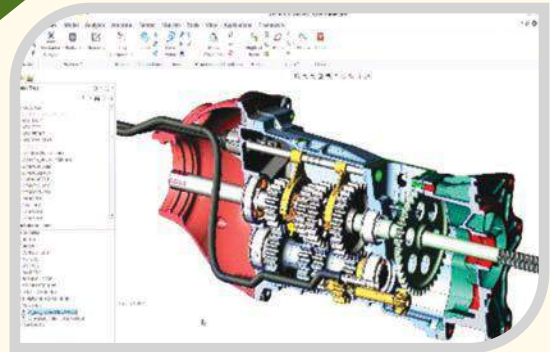

5. CATIA

- Sketcher & Constraint
- Part Design
- Wireframe & Surface Design
- Assembly & Kinematics
- Drafting & Detailing
- CATIA CAM

Duration : 1 Month (3hrs/ Day)

Course Fee : ₹.8,000/-

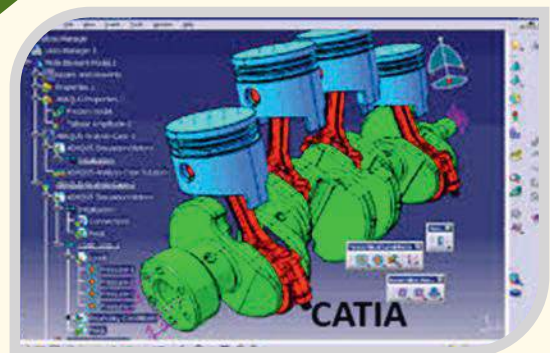

6. Additive Manufacturing & 3D Scanning

- Autodesk Fusion 360
- Reverse Engineering
- 3D Scanning
- 3D Printing (DMLS Metal, FDM Stratasys, DLP 3D System)
- CURA & Idea Maker

Duration : 6 hrs. Per day (1 Month)

Course Fee : ₹.10,000/-



7. SOLIDWORKS

- Sketcher & Constraint
- Part Design
- Wireframe & Surface Design
- Assembly & Kinematics
- Drafting & Detailing
- Core & Cavity Extraction

Duration : 1 Month (3hrs/ Day)

Course Fee : ₹.8,000/-





8. ANSYS

- Introduction to FEA & ANSYS
 - Structural Analysis (Linear, Non Linear, Dynamic)
 - Thermal Analysis (Steady State & Transient)
 - Couple Field Analysis
- ** All the above content will be covered using latest APDL & Workbench version

Duration : 15 Days (3hrs/ Day)

Course Fee : ₹.8,000/-

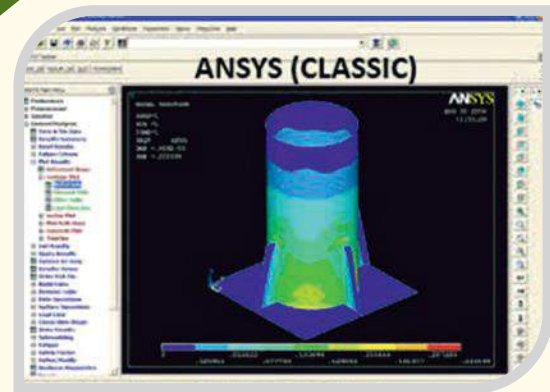

9. 3D Printing

- Introduction to Additive Manufacturing
- Comparison of Subtractive & Additive Manufacturing
- Classification of Additive Manufacturing
- New Technologies Used in the field of Additive Manufacturing
- Introduction to 3D Printing
- Technology Used & Advantage over Subtractive Manufacturing
- Demonstration of IdeaMaker
- Introduction to Idea 3D Printer
- Demonstration of 3D Printing Machine
- Demonstration of Metal 3D Printing Machine
- Working Procedure & Process Chain
- Post Processing Procedures
- Introduction to 3D Scanning
- Scan Data Creation & Scanning Methodology

Duration : 15 Days (3hrs/ Day)

Course Fee : ₹.8,000/-

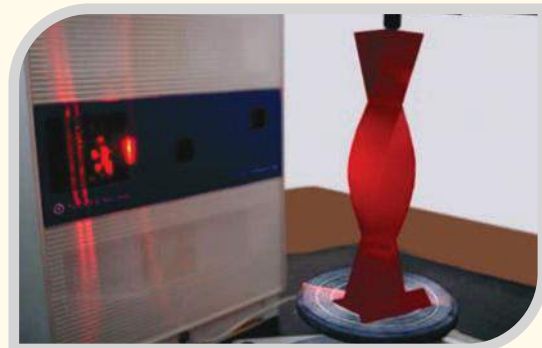
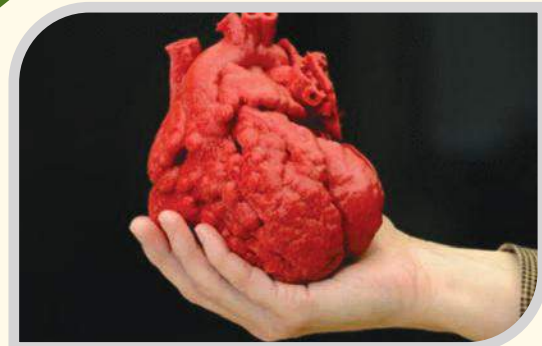

10. CNC TURNING & MILLING

- Introduction to CNC Technology
- NC & CNC Machines, Machine Parts & Types of Controllers
- G Codes & M Codes
- Basic Part Programming Techniques & Implementation of G Code & M Code
- Types of Cutting Tools, Tool Holders, Inserts & Selection of Cutting
- Tool for Particular Operation
- CNC Milling Machine Practice
- CNC Turning Machine Practice

Duration : 1 Month (3hrs/ Day)

Course Fee : ₹.8,000/-



TRAINING PROGRAMMES COURSES FOR ELECTRICAL/ ELECTRONICS OR EQUIVALENT ENGG.

1. VLSI

- Introduction of VLSI • Semiconductor Physics • Analog/ Digital Electronics, EDA Tools • CMOS & layout design using MICROWIND
- VHDL & Verilog HDL programming & simulation using XILINX & ALTERA QUARTUS • Interfacing of PLDs (SPARTAN, VIRETEX, CYCLONE)
- Analog circuit design and verification through FPAA using ANADIGM
- Basics of Microcontroller • Project Work

Duration : 1 Month (3hrs/ Day)

Course Fee : ₹.8,000/-

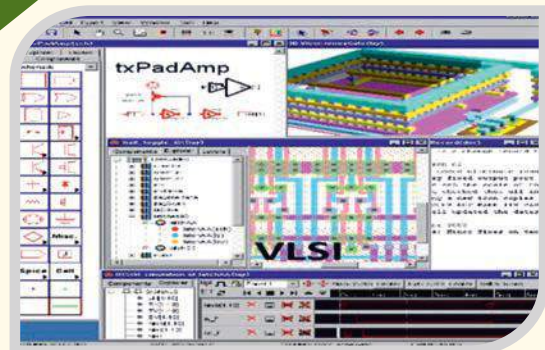

2. PLC PROGRAMMING

- Introduction to Automation & Safety • Details of Field Level Control and Applications • PLC Hardware details and configuration • IEC Programming Languages for PLC • Analog and Digital Process Programming • Practice on Industrial Logics • PLC Network Architecture • Interaction of PLC with Field Devices • Offline and Online Fault Monitoring

Duration : 1 Month (3hrs/ Day)

Course Fee : ₹.8,000/-



3. EMBEDDED SYSTEM

- Introduction to Embedded Systems • Assembly & Embedded 'C' Programming • Addressing of 8051 • P1C18 & ARM 7 using RIDE
- PROTEUS, MPLAB, KEIL & Crosswire • Interfacing of peripheral devices with 8051, p1C18 & ARM 7 • Project Work

Duration : 1 Month (3hrs/ Day)

Course Fee : ₹.8,000/-

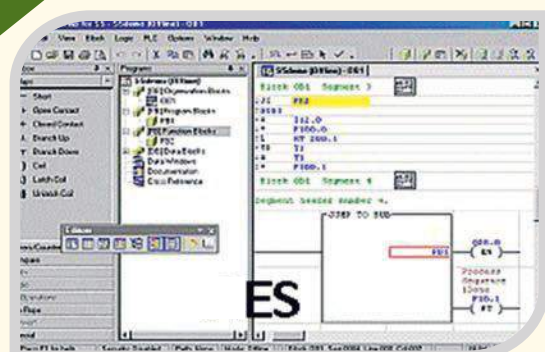

4. SCADA

- Introduction to Supervisory Control • Different Operation Levels of SCADA • Functionalities of SCADA • Hardware for SCADA System
- Software Interface • Creation of GUI & HMI Configuration
- SCADA Network Architecture • Data Acquisition and Report Generation
- GUI Interface with Control and Field Device

Duration : 1 Month (3hrs/ Day)

Course Fee : ₹.8,000/-

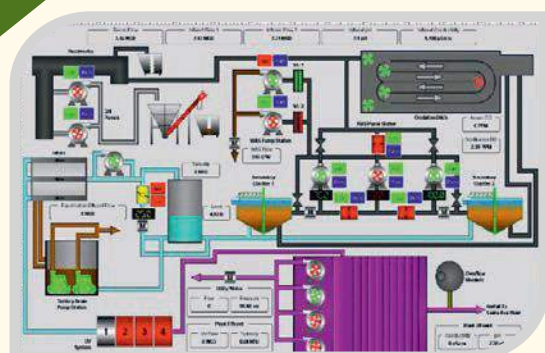



5. ELECTRICAL CAD

• Introduction of CAD • Importance of Electrical CAD • Co Ordinate System and 2D Drafting Features • 3D Drawing and Drafting • Electrical Circuits and Line Diagrams • Control and Power Circuit Drawing • Grid Designing with Transmission and Distribution • House Wiring and Panel Designing • Panel Designing with EPLAN • Report Generation

Duration : 1 Month (3hrs/ Day)

Course Fee : ₹. 8,000/-

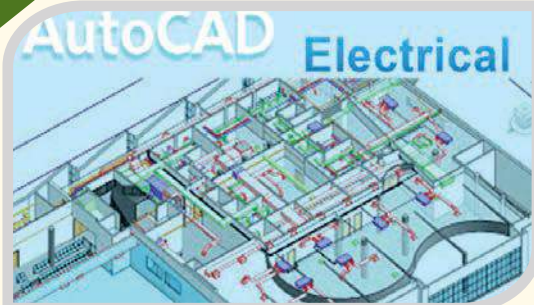

6. HYDRAULICS & PNEUMATICS

• Introduction to Fluid Engineering • Hydraulics and Pneumatic System • Safety and Operation of Pneumatics and Hydraulics • Components and Accessories for Pneumatics and Hydraulics • Different kinds of Valves and Actuators • Flow Diagram and Simulation Using Software • Practice with Physical Units • Electro Hydraulics and Pneumatics • Interface with PLC and OPC Server • Hydraulics and Pneumatics Fault Monitoring • Check list for Hydraulic and Pneumatic System Maintenance

Duration : 1 Month (3hrs/ Day)

Course Fee : ₹. 8,000/-

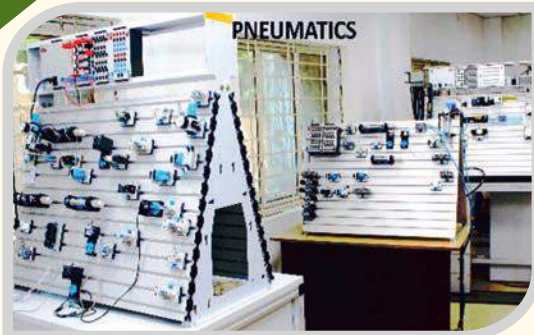

7. SURYAMITRA

Objectives : After completion of the course, the Trainees will be able to install & maintain a stand-alone or grid connected photo voltaic power system.

Job Role : Skilled Technician

Duration : 3 Months (300 Hrs.)

Course Content : Basic Electricals, Semiconductor Physics, Soldering Technique, Basic Terminology of Solar System, Fundamental of Solar PV cell & Panel, Entrepreneurship, Soft Skill, Troubleshooting of Solar PV System

Mode of Selection : First come first serve basis

Course Fee : ₹.12,000/-



8. PROCESS AUTOMATION

Eligibility : Degree/Diploma in Chemical/ Electrical/ Electronics/ Instrumentation/ Mechatronics, ETC or equiv.

Course Content : 1. Electrical Safety and Relay Logic, 2. Calibration of Sensors and Field Instruments, 3. Electrical CKT Design, 4. Electropneumatics Control, 5. PLC and HMI Programming, 6. P & ID Flow Diagram, 7. P, PI, & PID Control, 8. Level, Flow, Pressure, Temperature Loop Control, 9. Open and Close Loop Control, 10. Cascade and Ratio Control, 11. Commissioning and Trouble Shooting

Duration : 1 Month (3hrs/ Day)

Course Fee : ₹.8,000/-



9. MECHATRONICS

Eligibility : Diploma in Electrical/ Electronics/ Mechanical/ ETC/ Instrumentation or equivalent

Course Content : 1. Electrical Safety and Electrical Machines, 2. Application of industrial Sensors, 3. Electrical HW Logic Control, 4. Pneumatic and Hydraulic Control, 5. PLC and HMI, 6. Commissioning and Trouble Shooting

Duration : 1 Month (3hrs/ Day)

Course Fee : ₹.8,000/-



TRAINING PROGRAMMES COURSES FOR CIVIL ENGG.

1. AUTO CAD (CIVIL)

- Basic concept of Drawing
- Auto CAD 2D & 3D Building
- Inertial Design
- Working Drawing
- Steel Structure Detailed Drawing

Duration : 1 Month (3hrs/ Day)

Course Fee : ₹.7,000/-

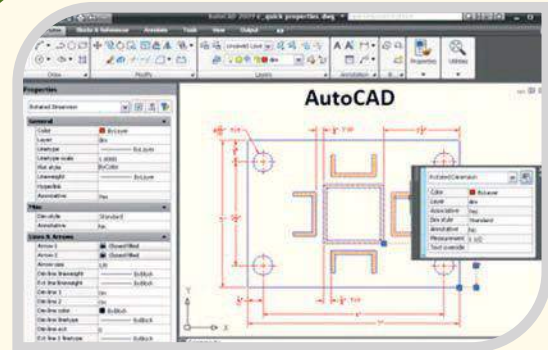

2. STAAD PRO

- Basic concept of 2D & 3D in Auto CAD
- Creating Geometry using different methods in X, Y, Z co-ordinates
- Defining about Beams, Column & Plates
- Support & Properties System
- Different Steel & Load Systems
- Analysis with concrete & steel

Duration : 1 Month (3hrs/ Day)

Course Fee : ₹.8,000/-

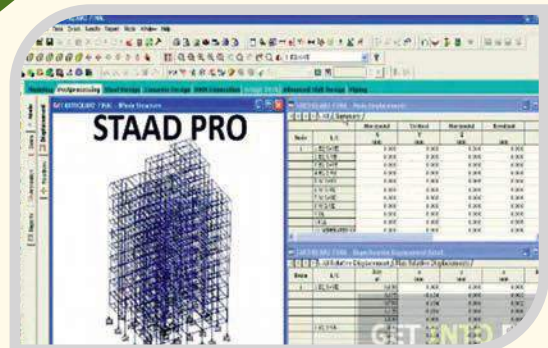

3. 3Ds Max

- Introduction to 3Ds Max
- Plan Conversion from Auto CAD
- Usage of Standard Primitives, Compound Object, Shapes
- Copy, Move, Rotate & other Standard Modification tools
- Creation of Door, Window, Stair, Railing, AEC Wall, Foilage
- Material Library, Command Panel
- Interior Design Techniques
- Types of Camera & Light, Rendering & Exporting

Duration : 1 Month (3hrs/ Day)

Course Fee : ₹.8,000/-

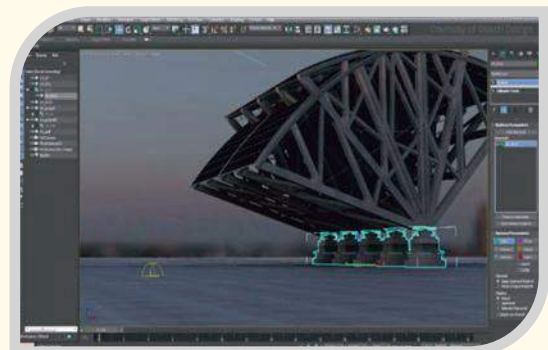

4. REVIT Architecture

- Introduction to REVIT
- Set up of Units & Element Properties
- Architectural Modelling
- Editing Tools & Managing Views
- Circulation Elements
- Annotating & Detailing
- Annotating Presentation Tools
- Rendering & Lighting
- Printing, Export/ Import

Duration : 1 Month (3hrs/ Day)

Course Fee : ₹.8,000/-





TRAINING PROGRAMMES SHORT TERM COURSES COURSES FOR ANY ENGG. STUDENTS/ GRADUATES

1. MAT LAB

- Parallel Computing
- Math, Statics & Optimization
- Control System Design & Analysis
- Signal Processing & Communications
- Test & Measurement
- Code Generation & Verification
- Application Development
- Database Connectivity & Reporting

Duration : 15 Days (3hrs/ Day)

Course Fee : ₹.8,000/-

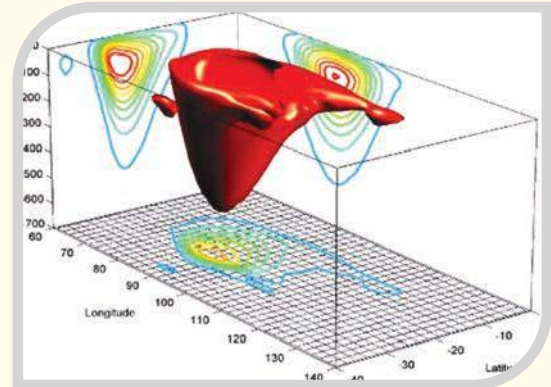

2. INTERNET OF THINGS (IOT)

- Introduction to IOT
- Physical & Logical Design of IOT
- IOT Enabling Technologies
- IOT Levels & Deployment Template
- Domain Specific IOTS
- M2M Communication
- IOT System Management.
- Platform Design Methodology Cloud Computing Data Analytics of IOT
- Python
- Hands on with Arduino, Raspberry Pi, ESP.

Duration : 1 Month (3hrs/ Day)

Course Fee : ₹.8,000/-

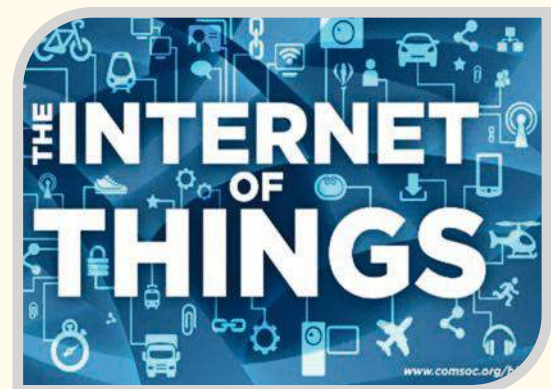

3. CORE JAVA

- Object oriented programming concepts
- Input & Output in JAVA
- Polymorphism
- Interface in JAVA
- Exception Handling
- SWING, Networking in JAVA
- JAVA Database Connectivity

Duration : 1 Month (3hrs/ Day)

Course Fee : ₹.5,500/-



4. Artificial Intelligence & Machine Learning

1. Python Programming
2. Data Analytics for Machine Learning
3. Supervised Learning
4. Unsupervised Learning
5. Artificial Neural Network
6. Computer Vision
7. Natural Language Processing

Duration : 1 Month (3hrs/ Day)

Course Fee : ₹.5,500/-

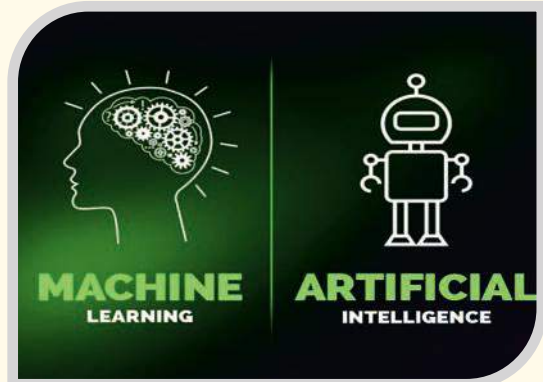

5. PROGRAMMING IN 'C'

- C Tokens
- Array
- Pointer
- String
- Pre Processor
- Control Statements
- Function
- Structure & Union
- Dynamic Memory Management
- File

Duration : 1 Month (3hrs/ Day)

Course Fee : ₹.3,500/-

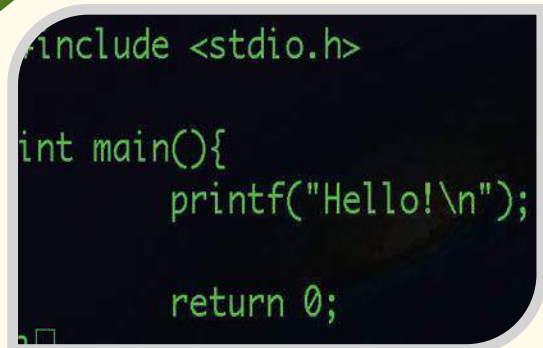

6. PROGRAMMING IN 'C++'

- Basic Syntax
- Array
- Pointer
- String
- Class & Objective
- Constructor & Destructor
- Virtual Function
- Template
- Control Statements
- Function
- Structure & Union
- Friend Function
- File
- Inheritance
- Name Space
- Exception Handling

Duration : 1 Month (3hrs/ Day)

Course Fee : ₹.3,500/-

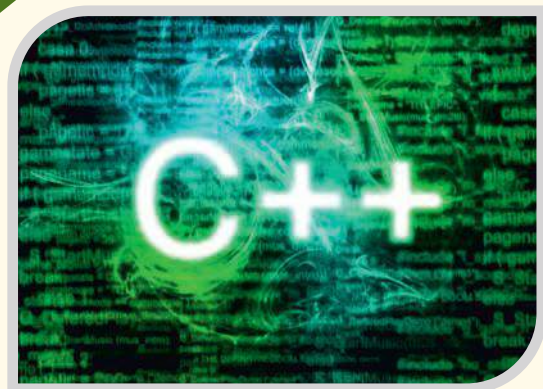

7. HARDWARE & NETWORKING

- Computer Fundamentals & MS DOS
- Computer Architecture
- Network Fundamentals
- System Management & Troubleshooting

Duration : 1 Month (3hrs/ Day)

Course Fee : ₹.5,500/-

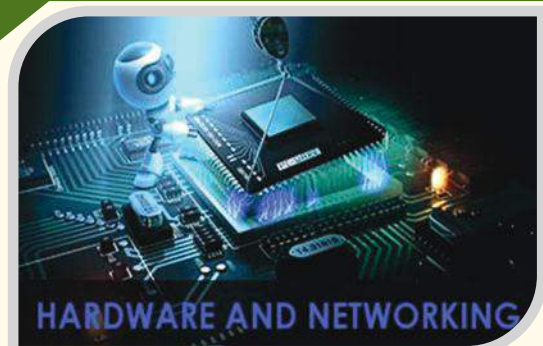



8. ENTREPRENEURSHIP DEVELOPMENT PROGRAMME

- Introduction to EDP
- Entrepreneurial Persons
- Entrepreneurial Communities
- Entrepreneurial Process
- What Does Entrepreneur Do?
- Entrepreneurship & Environment
- Business Terms
- Case Study on Business Secrets
- Steps in Planning New Facilities
- Selection of an appropriate form of Ownership Structure
- Search for Location
- Market Research
- Marketing Survey
- Barriers in Business
- Problem Solving Techniques



Duration : 1 Month (3hrs/ Day)

Course Fee : ₹.3,000/-

9. DATA ANALYTICS

- Microsoft excel (Advanced) Basic Excel, Working with Functions, working with data, pivot table, charts, add-ins.
- Data wrangling with SQL(SQL select statements, SQL functions and expression, SQL updating commands, SQL joins, SQL subqueries and unions.
- TABLEAU (Introduction to tableau, creating charts in Tableau analytics, creating dashboard, stories and publishing dashboards.
- Data analysis with Python (Data analytic packages NUMPY, PANDAS, MATPLOTLIB, SEABORN Machine Learning with Python, Time Series Forecasting, Introduction to Deep Learning

Duration : 1 Month (3hrs/ Day)

Course Fee : ₹.5,600/-



10. WINDOWS SERVER ADMINISTRATION

1. Network Essential & Windows Server Setup
2. ADDS Services & Domain Configuration
3. User & Group Policy Management
4. Permissions, FSRM, DNS & DHCP
5. IIS, WDS, & Hyper-V
6. FSMO Roles & Remote Access
7. Wi-Fi, N Computing

Duration : 1 Month (3hrs/ Day)

Course Fee : ₹.5,500/-



11. SAP BUSINESS ONE

Duration : 8 Days (3hrs/Day)

Course Fee : ₹.5,000/-

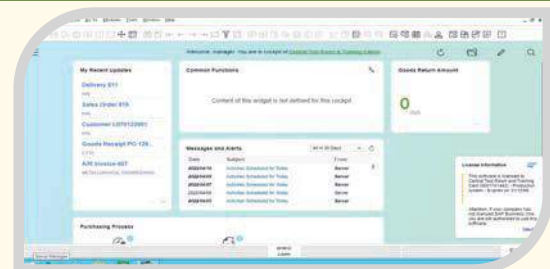

12. CLOUD COMPUTING

1. Introduction to Cloud Computing
2. Cloud Service Models
3. VM with AWS
4. Amazon Elastic Compute Cloud
5. IAM Roles
6. Hosting Website and Servers
7. Block Store & EBS Volumes
8. S3 Bucket, Storage and Load Balancing
9. Redshift Cluster
10. VPC Network

Duration : 1 Month (3hrs/ Day)

Course Fee : ₹.5,600/-

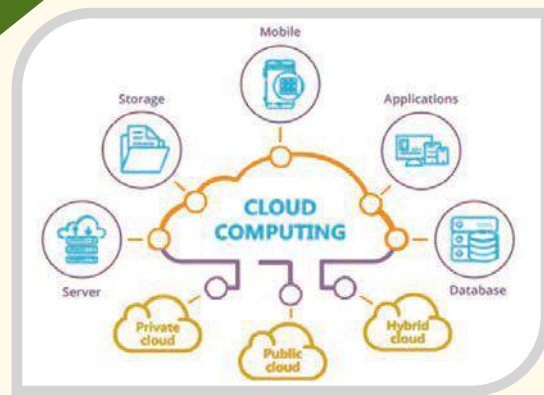

13. COMMUNICATION SKILL

1. Introduction to the World of Soft Skill
2. Identifying self Personality
3. Self Assessment Model Tests
4. Presentation & Public Speaking
5. Multiple Intelligence Check
6. Group Discussion
7. HR Interview Techniques
8. Thematic Apperception Test

Duration : 1 Month (3hrs/ Day)

Course Fee : ₹.3,000/-



14. PYTHON

1. Basic Python
2. Object Oriented Programming
3. Database Programming
4. Django
5. Introduction to Machine Learning Packages
6. Project using Django

Duration : 1 Month (3hrs/ Day)

Course Fee : ₹.5,500/-



15. TRAINING OF TRAINERS FOR TECHNICAL INSTITUTE



SCHEDULE: EACH SHORT TERM COURSE STARTS ON 1ST WORKING DAY OF EVERY MONTH



SAMSUNG INDIA Along with CTTC, Bhubaneswar Offer Following Courses for Advanced Repair & Industrial Skill Enhancement



1. Hand Held Product

- Introduction to Basic Phone, Smart Phone, Note Series, Tablet etc.
- Demonstration, Circuit Diagram
- Trouble Shooting/Fault Finding/Customer Handling
- Soldering & Disordering (Hi-end)

Duration : 3 Months (6hrs/ Day)

Course Fee : ₹.15,500/-



2. Room Air Conditioner & Home Appliances (RACHA)

- RACHA Basics
- Installation, Demonstration, Circuit Diagram
- Trouble Shooting & Error Codes
- Gas Changing, Compressor Handling

Duration : 4 Months (6hrs/ Day)

Course Fee : ₹.20,500/-



3. LED, LCD, Plasma TV, Home Theatre (A-V)

- Introduction to TV & Home Theatres
- Installation, Demonstration, Circuit Diagram
- Trouble Shooting & Error Codes finding
- Soldering & Error Handling

Duration : 3 Months (6hrs/ Day)

Course Fee : ₹.15,500/-

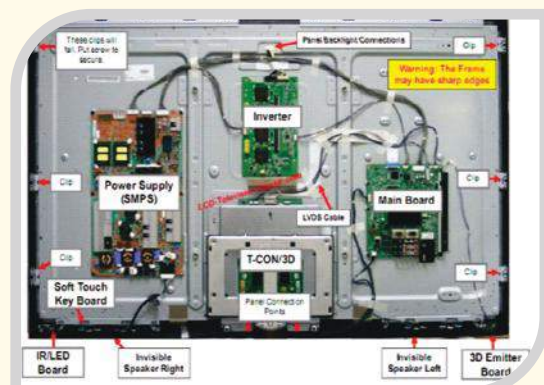

ELIGIBILITY FOR SAMSUNG ARISE COURSES: +2 Science/ ITI/ Diploma/ B.Tech in any Branch

Infrastructure at a Glance:

- Modern Tool Room with latest CNC Machines
- Training centre with more than 60 conventional machines, 50 CNC Machines and more than 3000 latest configured computers.
- 62 CAD/CAM/Electrical/Electronics/VLSI Labs
- Design & Development using modern CAD/CAM systems
- Area covered 12.9 acres
- Vacuum Heat Treatment Plant (ALD, Germany)
- 3D Metal Printing Machine
- 3D Plastic Printing Machine
- 5-Axis Milling Machine
- Turn-Mill Machining Centre
- 5-Axis Ultrasonic Machine
- Limited Hostel facility for Boys & Girls

Jig Grinding Machine (Accuracy – 0.3 Micron)



ELECTRONICS BLOCK



INTERNATIONAL HOSTEL



3D Metal Printing Machine



CNC EDM

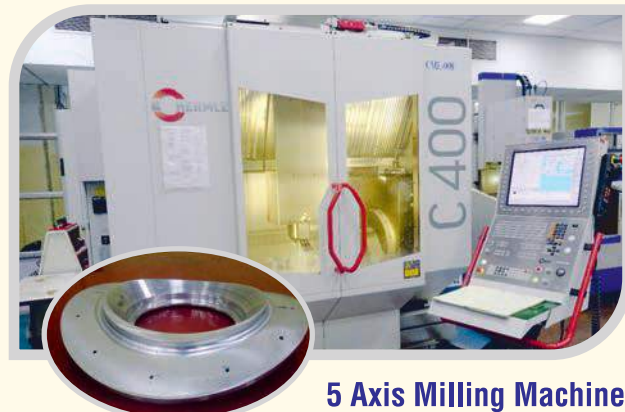

5 Axis Milling Machine



Facilities Available:

- Class room with modern Audio Visual equipment viz. Interactive Board, LCD, OHP, DVD DigiCAM, Video Camera, Plasma TV etc.
- 24 Hours Computer Lab exclusively for Trainees.
- Dedicated 200 Mbps leased line Internet connection
- Inspection department for inspecting the exercise done by the trainees.
- Full-fledged library equipped with books, manuals, catalogues, magazines & journals.

Faculties:

Professionally qualified, experienced and overseas trained full time faculties are engaged in teaching theory & practical.



Placement Cell:

The Placement Cell handles all aspects of Campus placements for the eligible students at CTTC, Bhubaneswar. The centre is well equipped with excellent infrastructure to support every stage of the placement process. Arrangement for Pre- placement Talks, Group Discussions, Interviews etc. are handled by Placement Cell.





GENERAL INFORMATION

ADMISSION CRITERIA

Eligible candidates will be offered admission on first-cum-first-serve basis for selected courses on depositing Registration Fees (As per Course Details) by DD in favour of Central Tool Room & Training Centre, Bhubaneswar along with filled Admission Form. Admission Form along with prospectus can be obtained in person from CTTC, Bhubaneswar or on a request for Admission Form through E-Mail by giving full postal address. The Registration Fee will be adjusted towards course.

- Admission are open for Boys & Girls.
- Admission Process for Individual courses as indicated in Course Details.
- No Tuition Fees for SC/ST candidates (only for Medium & Long Term Courses) - 22.5% seats are reserved for SC/ST category.
- Candidates belonging to reserved category should substantiate their claim by enclosing a Caste Certificate issued by competent authority.

HOSTEL ACCOMMODATION

Separate Hostel Facilities may be provided for outstation boys & girls subject to availability of the accommodation at the discretion of the institute on extra cost as applicable.

RULES FOR AWARDING OF CERTIFICATE

The evaluation system consists of continuous assessment of each module subject to assess the performance of the trainee. Trainee should have minimum 80% attendance.

GENERAL RULES & REGULATIONS FOR TRAINEES

- CTTC reserves the right to reject any application without assigning any reason. Incomplete applications are liable to be rejected.
- Registration Fee is Non Refundable, in case any candidate cancels his admission for any reason.
- Admission to the course will be given only on deposition of first instalment fees by DD & on submission of relevant documents.
- Course Fee once paid will not be refunded under any circumstances.
- Registration/ Course Fee is not transferrable.
- Course Fee for higher/ next semester has to be paid within one week from the starting date of semester & all the candidates belonging to SC/ ST category are required to fill in fresh application form for fee exemption claim, within one week from the starting date of new semester. Late fee will be charged as a fine from the due date as applicable.
- Insurance & other charges as specified for the course to be paid but the trainee in addition to the course fee as applicable.
- Security deposit shall be forfeited in case of loss of original receipt of the security deposit.
- All the trainee will be ensure discipline within the campus.
- Trainee shall be required to wear uniform & shoes as prescribed by the institute and possess I-Card compulsory during training.
- Mobile Phones, Pen Drives, CD any other related items are not permitted inside CTTC premises.
- Regular attendance will have to be maintained by the trainee as per course schedule & 80% attendance is compulsory in all subjects individually.
- Trainees will abide by the examination rules and regulations displayed on Notice Board of CTTC and as amended.
- Leave without information/ permission will not be entertained.
- Trainees going on leave or home during vacation should inform course coordinator compulsorily.
- All the internal assessments, assignments, evaluation will have to be attended/ completed from time to time as per course schedule only.
- No trainee shall be organize/ conduct any meeting within the campus.
- The Machines/ Equipment/ Furniture must be handled carefully. No act of damage to CTTC property shall be carried out by the trainee, any loss or damage to property, including water & electricity usage.
- Smoking & chewing tobacco, possessing or drinking alcoholic beverages in any form is strictly prohibited within CTTC premises.
- Ragging is strictly prohibited in the premises.
- Writing any Comment/ Remarks/ Name on doors, walls, toilet, and notice board is strictly prohibited.
- Study material will be provided on extra cost as applicable.
- Working hours will be 8hrs/day (excluding lunch) in different shifts/ timing as prescribed by the institute.
- Violation of above & any other Rules, Regulations, Disciplines and Conduct are liable for disciplinary action.

“Specializing people all over the world”

Government of India is sharing the technology to other different countries. CTTC, Bhubaneswar offered various Skill Development Programmes in CAD/CAM, tool design & manufacturing, VLSI, hydraulics & pneumatics, PLC & advance networking etc areas for 25 Countries with Turn Key Project in 7 Highlighted Countries.

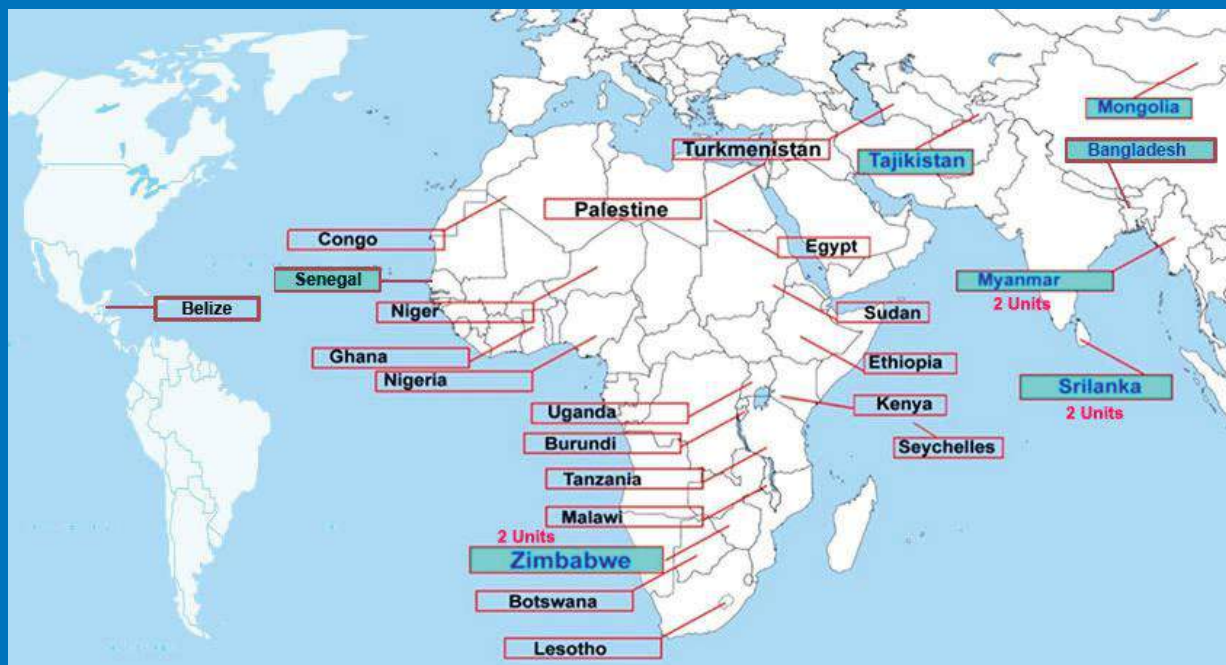



सत्यमेव जयते
MINISTRY OF MICRO, SMALL & MEDIUM ENTERPRISES
GOVERNMENT OF INDIA

MSME TOOL ROOM

Ministry of Micro, Small & Medium Enterprises (Govt. of India)

B-36, Chandaka Industrial Area, Near Infocity
Bhubaneswar-751024, Odisha, India

Phone : 0674-2654770/700, 2654742/743

Fax: 0674-2654768

Email: cttc@cttc.gov.in, Website: www.cttc.gov.in

